

Hygard BR1250 PRODUCT DETAILS

Tuffak Hygard BR1250 laminate is a four-ply Tuffak polycarbonate sheet for use in security applications that require UL Listed Level III bullet-resisting glazing. Tuffak Hygard BR1250 laminate is hard coated with abrasion and UV resistant surfaces for extended service life in hard environments.

Typical Physical Properties	
Gauge/Tolerance	1.30 ± 5%
Weight	8.1 lbs./s.f.
Shading Coefficient	.81
% Light Transmittance	67% (clear)
Colors Custom Colors on request	Standard: Clear
Sheet Sizes	Standard: 38" x 96" 48" x 60" 48" x 96" 48" x 72" 60" x 96" Custom Sizes on request

APPLICATIONS

Tuffak Hygard BR1250 laminate is used as containment and bullet-resistant glazing in a wide variety of high level security applications. Installations include 24 hour convenience stores, specialty retailers, banks, governmental and detention facilities, as well as other cash transaction areas.

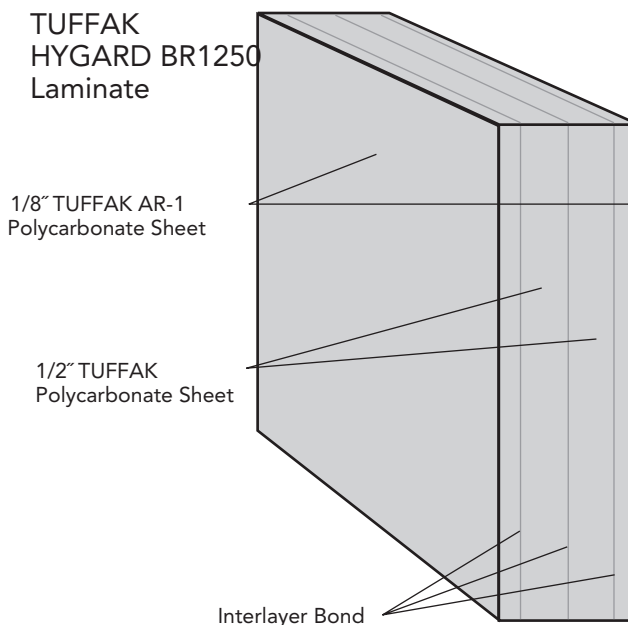

FORCED ENTRY, BALLISTICS RATINGS

H.P. WHITE TP0500.01 LEVEL V
H.P. WHITE TP0500.01 LEVEL C BALLISTICS (.44 magnum)
ASTM F 1233 CLASS V STEP 38 BALLISTICS (.44 magnum)
UL752 Level III SPSA .44 Magnum

Glazing Information

- Use of structural security framing systems with equal or greater forced entry and/or ballistics ratings as the selected Tuffak Hygard Laminate is recommended.
- Size Tuffak Hygard laminates to allow for a minimum of 1" edge engagement in the frame, with sufficient rabbet depth for material expansion (approx. 1/16"/ft)
- Use wet or dry sealants/gaskets that are compatible with polycarbonate.
- Remove protective masking after glazing operations are completed and before prolonged exposure to direct sunlight, moisture, or high temperature.

Cleaning Instructions

- Rinse with clean water to remove abrasive dust and dirt.
- Wash with soap or mild detergent using a sponge or soft cloth. Do not scrub.
- Rinse once more. Dry with soft cloth or chamois to prevent water spots.
- To remove labels, stickers, or grease, rub gently with a cloth wetting thoroughly in VM&P naphtha or isopropyl alcohol. Wash and rinse. Do NOT use razor blades, scrapers, or squeegees.

Product Specification

TUFFAK HYGARD BR1250 laminate:
Four-ply, clear TUFFAK polycarbonate sheet constructed as follows:

- 1/8" TUFFAK polycarbonate sheet with high AR abrasion-resistant surface
- Polyurethane bonding interlayer
- 1/2" TUFFAK polycarbonate sheet
- Polyurethane bonding interlayer
- 1/2" TUFFAK polycarbonate sheet
- Polyurethane bonding interlayer
- 1/8" TUFFAK polycarbonate sheet with high AR abrasion-resistant surface

Material shall have a flexural strength of at least 13,500 psi per ASTM D-790; and shall have AR (high performance abrasion-resistant) surfaces for enhanced service life and resistance to marring. Material shall exhibit a self ignition temperature of 1077°F and a flash ignition temperature of 872°F (ASTM D-1929), and conform with ICBO & BOCA Model Building Codes as a CC-1 rated Approved Light Transmitting Plastic.